

AMD Opteron™ 6100 Series Processor

What's new in the AMD Opteron™ 6100 Series Processor (Codenamed "Magny-Cours")?

Platform	Processor	Socket	Chipset
Opteron 6000 <i>(codenamed "Maranello")</i>	Opteron 6100 <i>(codenamed "Magny-Cours")</i>	G34	56x0 / 5100

- **8- or 12-Core AMD Opteron™ Processors on the AMD Opteron 6000 Series platform (Socket G34, codenamed "Maranello" with the AMD SR56x0 / SP5100 Chipset)**
- **New Power Management Features**
 - **Cool Speed**
Cool Speed protects processor integrity by reducing power states when a temperature limit is reached
 - **C1E**
Promotes significant power savings. C1E detects when processor cores are idle: HyperTransport links are powered down, and the cores go into a deeper sleep state.
 - **Enhanced APMML with Precision Thermal Monitor**
APML is the interface for monitoring and controlling system resources, and Precision Thermal Monitor closely monitors power/cooling, and proactively alerts the Base Management Controller (BMC).
- **Memory: Quad Channel U/RDDR3 at 800MHz, 1066MHz, and 1333MHz**
- **HyperTransport: 4x HT3 (HT 3.0), with up to 25.6 GB/s at 6.4 GT/s per link**
- **Cache: 12MB L3 cache per socket**

The server platform you can count on as real-world workloads become increasingly complex and demanding



AMD Opteron™ 6100 Series Processor

Series Transitions: AMD Opteron Server Roadmap

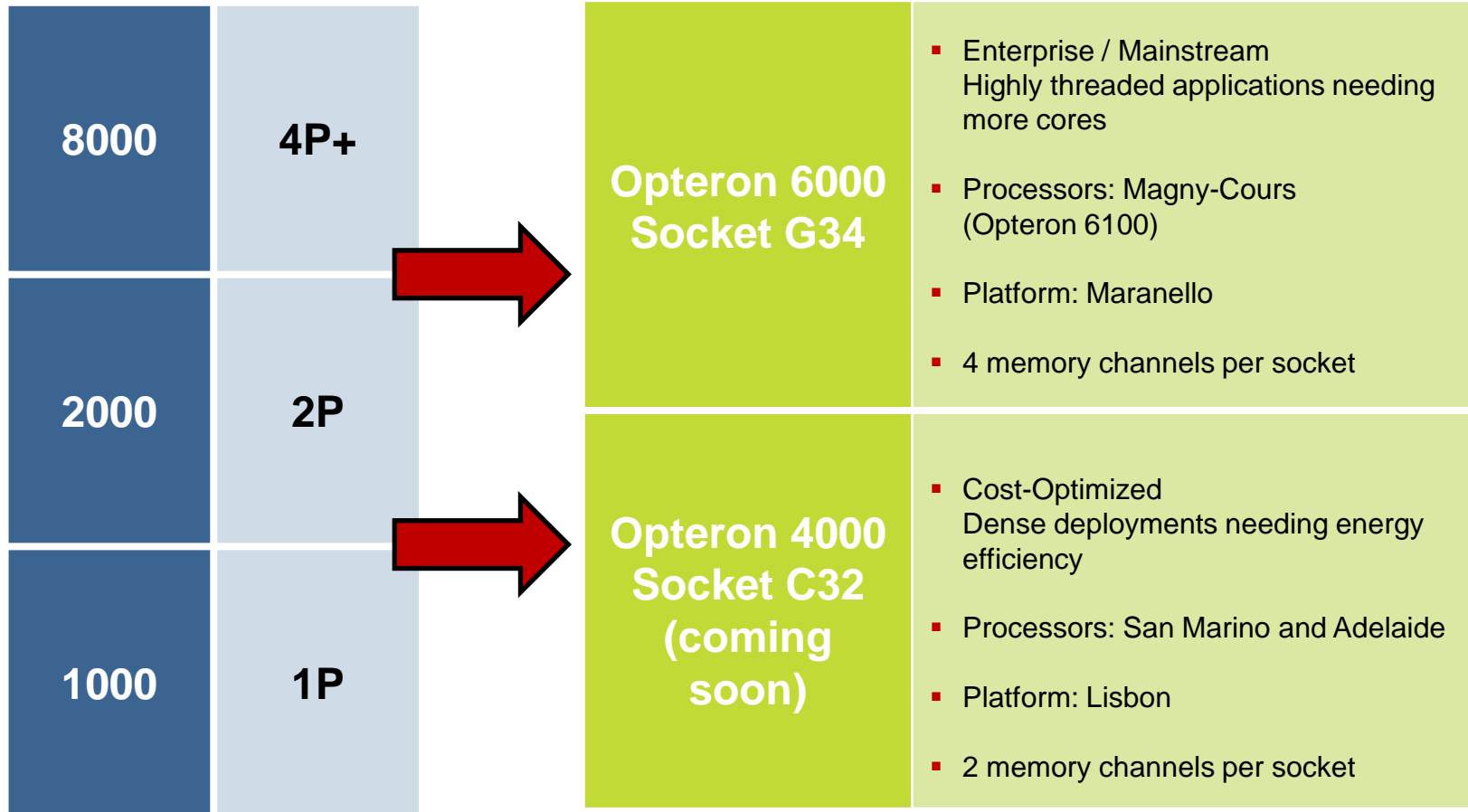

Expert included.



AMD Opteron™ 6100 Series Processor

Product Specifications

Process	ACP ¹	Model	Clock Frequency / NB Frequency (GHz)	Cores	L2 Cache	L3 Cache	Max Memory Speed	System Bus Speed
45nm	105W	6180 SE	2.5 / 1.8	12	12 x 512KB	12MB	1333MHz	6.4GT/s
		6176 SE	2.3 / 1.8					
	80W	6176	2.3 / 1.8	12	12 x 512KB	12MB	1333MHz	6.4GT/s
		6174	2.2 / 1.8					
		6172	2.1 / 1.8					
		6168	1.9 / 1.8					
		6140	2.6 / 1.8	8	8 x 512KB	12MB	1333MHz	6.4GT/s
		6136	2.4 / 1.8					
		6134	2.3 / 1.8					
		6128	2.0 / 1.8					
	LOW POWER 65W	6166 HE	1.8 / 1.8	12	12 x 512KB	12MB	1333MHz	6.4GT/s
		6164 HE	1.7 / 1.8					
		6132 HE	2.2 / 1.8	8	8 x 512KB	12MB	1333MHz	6.4GT/s
		6128 HE	2.0 / 1.8					
6124 HE		1.8 / 1.8						

¹ ACP stands for Average CPU Power.

AMD Opteron™ 6100 Series Processor

Processor Block Diagram for 2P Mainboards

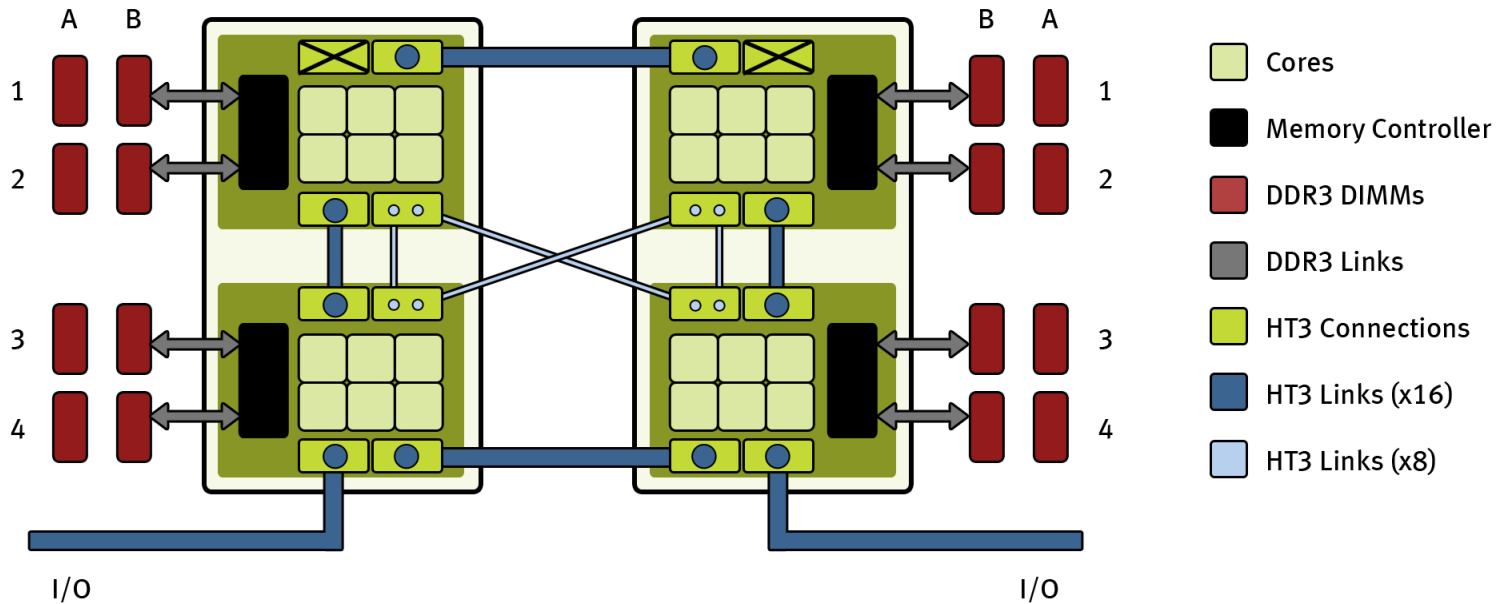

Expert included.



AMD Opteron™ 6100 Series Processor

Processor Block Diagram for 4P Mainboards

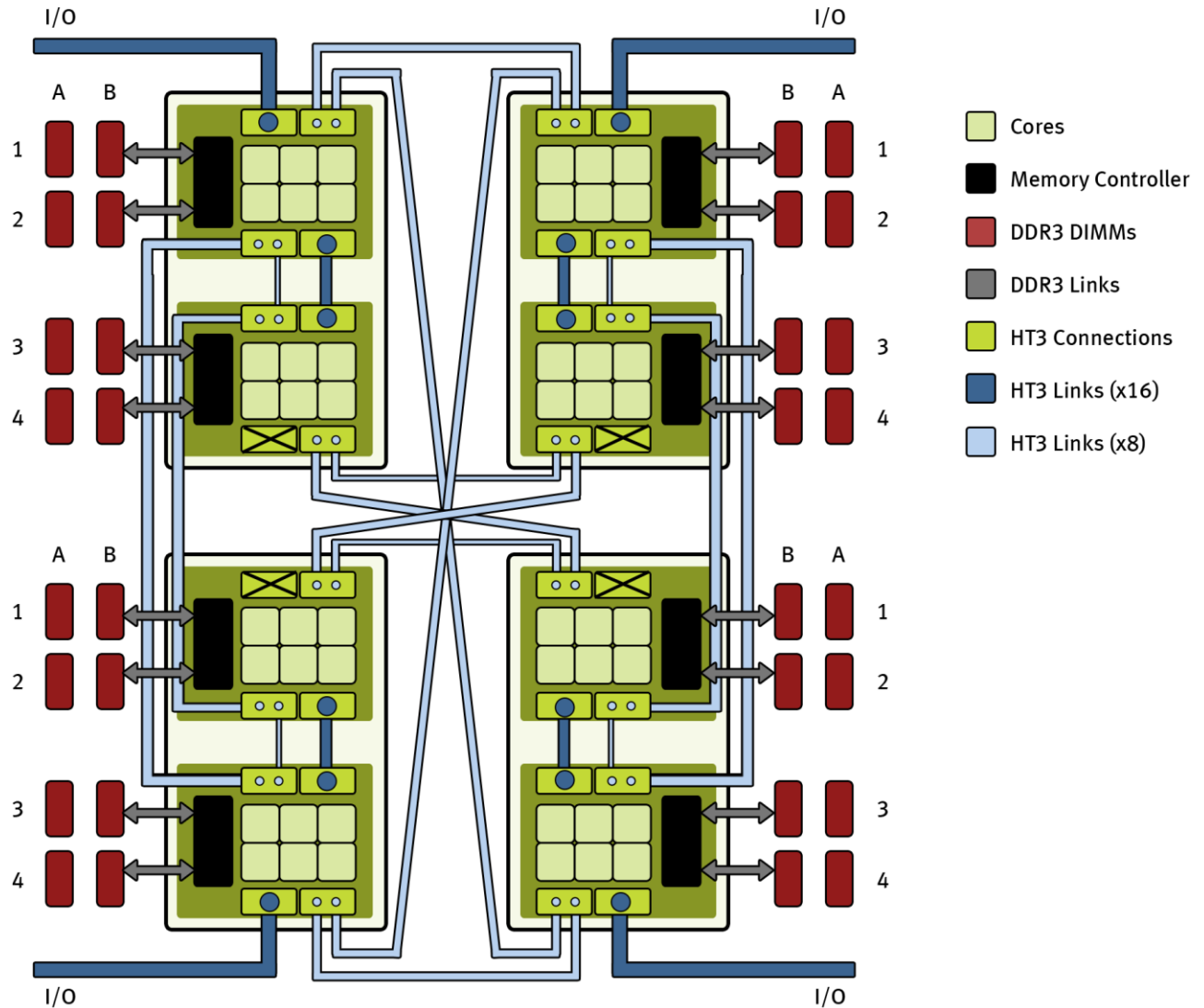

Expert included.



AMD Opteron™ 6100 Series Processor

Memory Population Guidelines: 2 DIMMs per channel

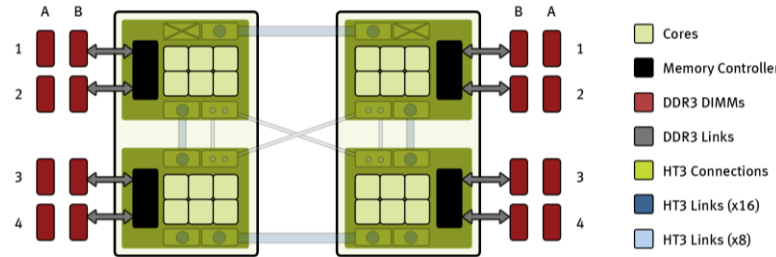

Mainboards with 2 DIMMs per Channel¹

	DIMM Bank A	DIMM Bank B	Max MHz, 1.5V DIMMs	Max MHz, 1.35V DIMMs	Max GB/Channel
UDIMM	1R or 2R	Empty, 1R or 2R	1333	1066	8GB
RDIMM	1R or 2R	Empty, 1R or 2R	1333	1066	16GB
	4R	Empty	1333	1066	16GB
	4R	1R, 2R, or 4R	1066	800	32GB

¹ AMD supports single, dual, and quad rank (1R, 2R, and 4R). There is no distinction between memory population scenarios for 2P and 4P servers.



AMD Opteron™ 6100 Series Processor

Memory Population Guidelines: 3 DIMMs per channel

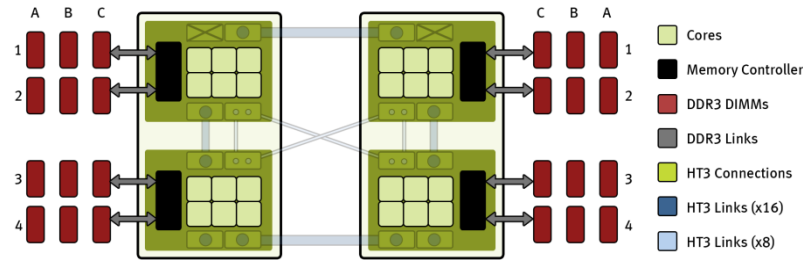

Mainboards with 3 DIMMs per Channel¹

	DIMM Bank A	DIMM Bank B	DIMM Bank C	Max MHz, 1.5V DIMMs	Max MHz, 1.35V DIMMs	Max GB/Channel
UDIMM	1R or 2R	Empty	Empty, 1R or 2R	1333	1066	8GB
RDIMM	1R	1R	1R	1333	1066	12GB
	1R or 2R	Empty	Empty, 1R or 2R	1333	1066	16GB
	2R	1R or 2R	1R or 2R	1066	800	24GB
	Empty	4R	Empty	1066	1066	16GB
	1R or 2R	4R	Empty	800	800	24GB
	1R or 2R	4R	1R or 2R	800	667	32GB

¹ AMD supports single, dual, and quad rank (1R, 2R, and 4R). There is no distinction between memory population scenarios for 2P and 4P servers.

Expert included.



AMD Opteron™ 6100 Series Processor

HT3 Connections for 2P Mainboards

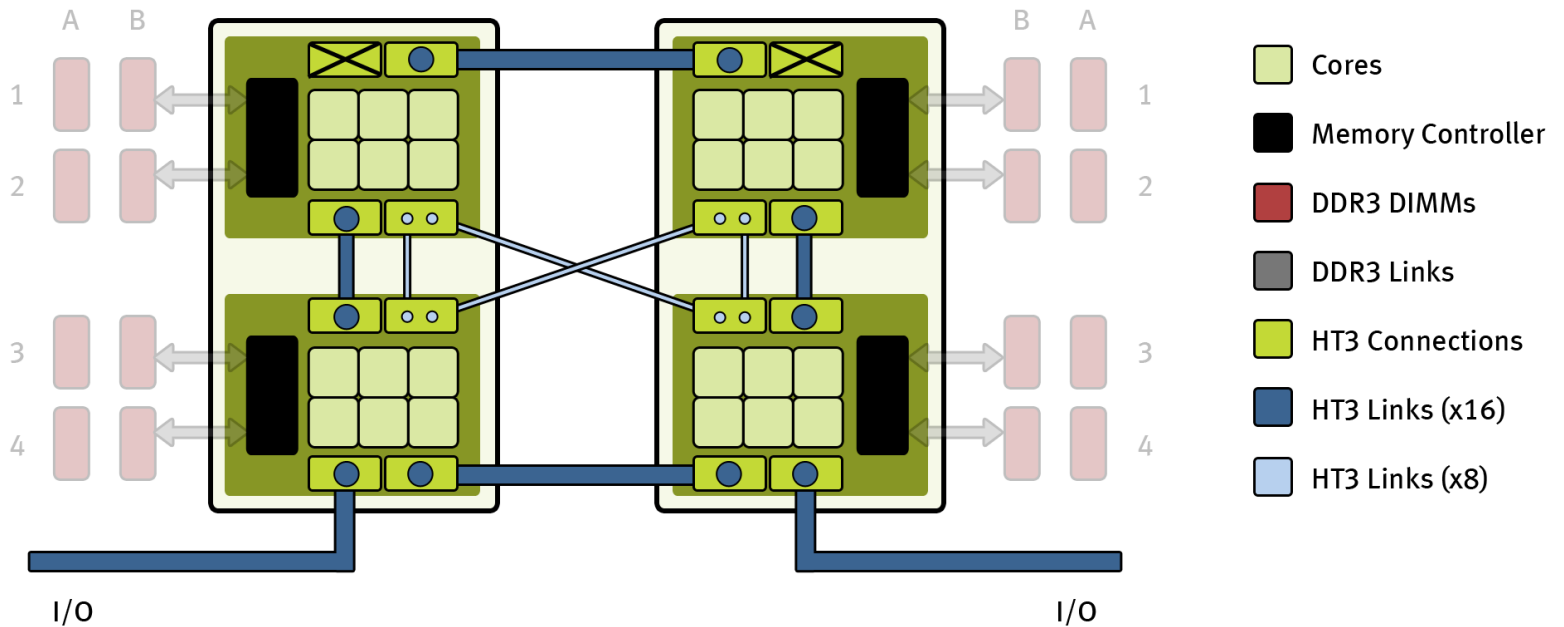

Expert included.



AMD Opteron™ 6100 Series Processor

HT3 Connections for 4P Mainboards

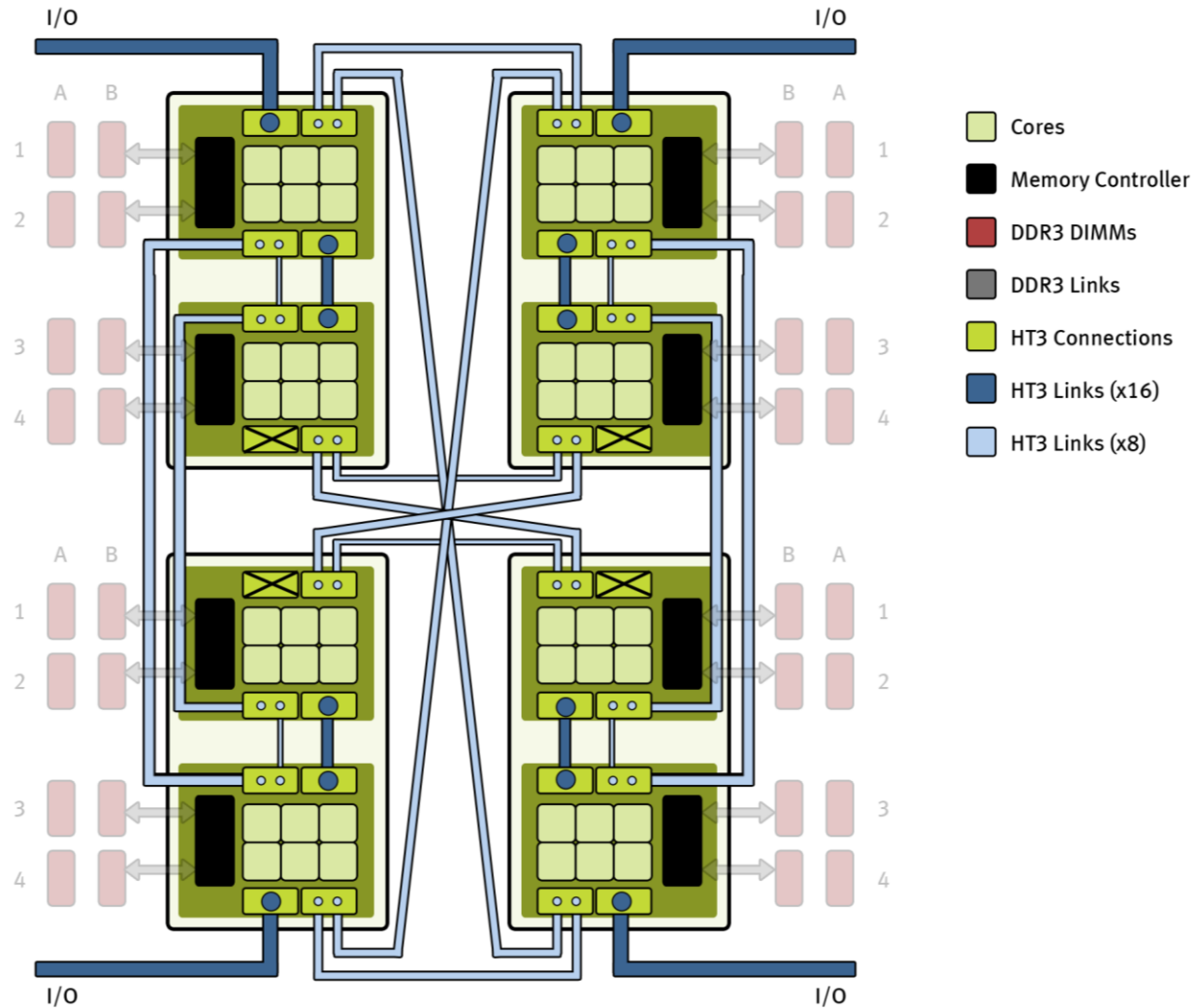

Expert included.



AMD Opteron™ 6100 Series Processor

Servers with the AMD Opteron 6100 Series

- [Rackform nServ A161](#)
- [Rackform nServ A331](#)
- [Rackform nServ A335](#)
- [Rackform nServ A346](#)
- [Rackform nServ A350](#)
- [Rackform nServ A362](#)
- [Rackform nServ A4410](#)
- [Rackform nServ A4410-IB](#)
- [Rackform nServ A413](#)
- [Rackform nServ A422](#)

Storage Servers with AMD Opteron 6100 Series

- [Storform nServ A513](#)
- [Storform nServ A515](#)
- [Storform nServ A516](#)
- [Storform nServ A518](#)

Expert included.



Updated February 2011

AMD Opteron™ 6100 Series Processor

Contact Silicon Mechanics

For answers regarding processor selection or other questions,
contact one of the Experts at Silicon Mechanics:

Email: sales@siliconmechanics.com

Toll Free: 866.352.1173

www.siliconmechanics.com

Expert included.

